

Power Switch – PP23S76

Featured

- Typical 60 mΩ On Resistance
- Input Voltage: 3.0 V to 5.5 V
- Support Active-High Enable EN
- Support Active-Low Enable ENb
- Built-in Soft-Start
- Output Discharge when Switch Disabled
- True Reverse Blocking when Switch ON or OFF
- Output Over Current Protection
- Over Temperature Protection
- Fault Flag Output
- Halogen Free and Green Devices (RoHS Compliant)
- UL Listed File No. E536062

Applications

- USB Power Management
- USB type-A Vbus power
- High-Side Power Protection Switches
- Notebook and Desktop Computers

General Description

The PP23S76 is a low RDS(ON), up to 3 A low loss power distribution switch with fixed current limit to protect the power source from over current or short circuit conditions. The power switch is controlled by an on/off input (EN/ENb), which is capable of interfacing directly with low-voltage control signals. A 170 Ω on-chip load resistor is added for output discharge when switch is turned off.

The FLAGb pin is an open drain output that asserts (active low) when over-current or over-temperature event. The FLAGb signal remains asserted until the fault condition is removed and the device resumes normal operation. The PP23S76 is designed to eliminate false fault reporting by using an internal deglitch circuit

PIN Configuration

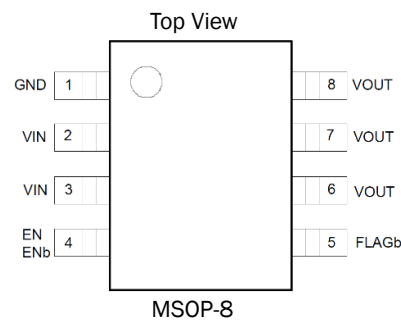
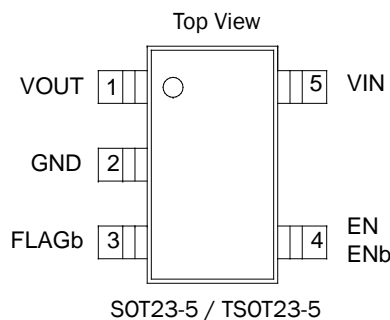

PIN Description

PIN		Name	Description
SOT23-5	MSOP-8		
1	6-8	VOUT	Power distribution switch output.
2	1	GND	Ground.
3	5	FLAGb	Active-low open-drain output, asserted during over temperature or current limit conditions.
4	4	EN	ON/OFF control. Active High for PP23S76A/C/E/G/I/K. Do not leave floating.
		ENb	ON/OFF control. Active Low for PP23S76B/D/F/H/J/L. Do not leave floating.
5	2,3	VIN	Input voltage. Bypass this input with a ceramic capacitor to GND.

Power Switch – PP23S76

Function Block Diagram

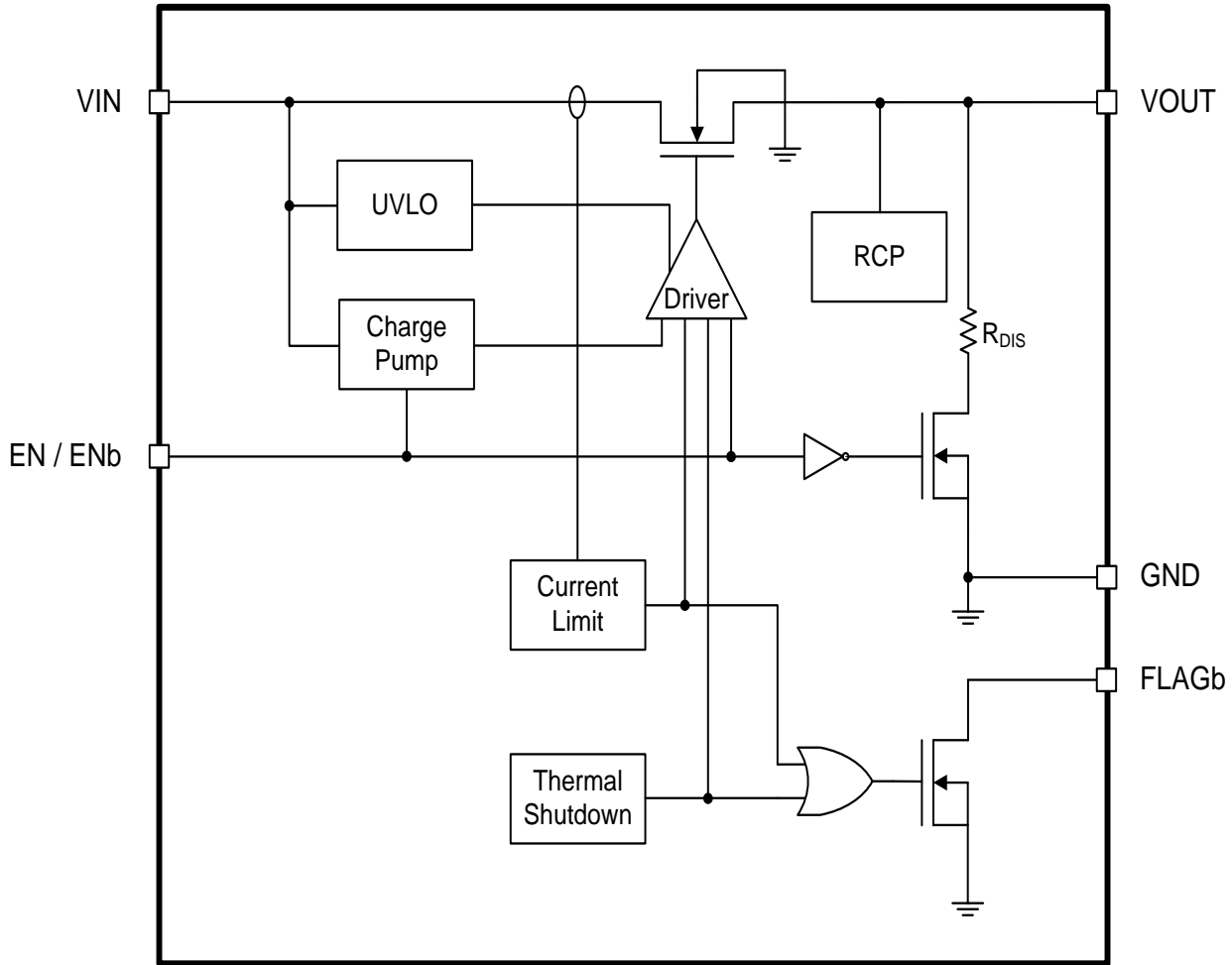

Power Switch – PP23S76

Application information & Circuit

◆ Thermal Protection

PP23S76 has internal over temperature protection to monitor the operating temperature of the power distribution switch and disables operation if the temperature exceeds recommended operating conditions, and FLAGb is pulled low to indicate fault condition. The device goes to power-up when die temperature decreases by 20 °C.

◆ Reverse Current / Voltage Blocking Protection

The PP23S76 integrates true reverse-current blocking which protects the input source against current flow from output to input regardless of the switch is on or off. When the switch turns on, whenever the output voltage is higher than the input voltage by 60mV (typ.), the MOSFET switch will turn off immediately.

◆ FAULT Response

The FLAGb open-drain output is asserted (active low) either over current, and over temperature conditions. The FLAGb signal remains asserted until the fault condition is removed and the device resumes normal operation. PP23S76 is designed to eliminate false overcurrent fault reporting by using an internal deglitch circuit.

Connect FLAGb with a pull-up resistor to VIN. FLAGb can be left open or tied to GND when not used.

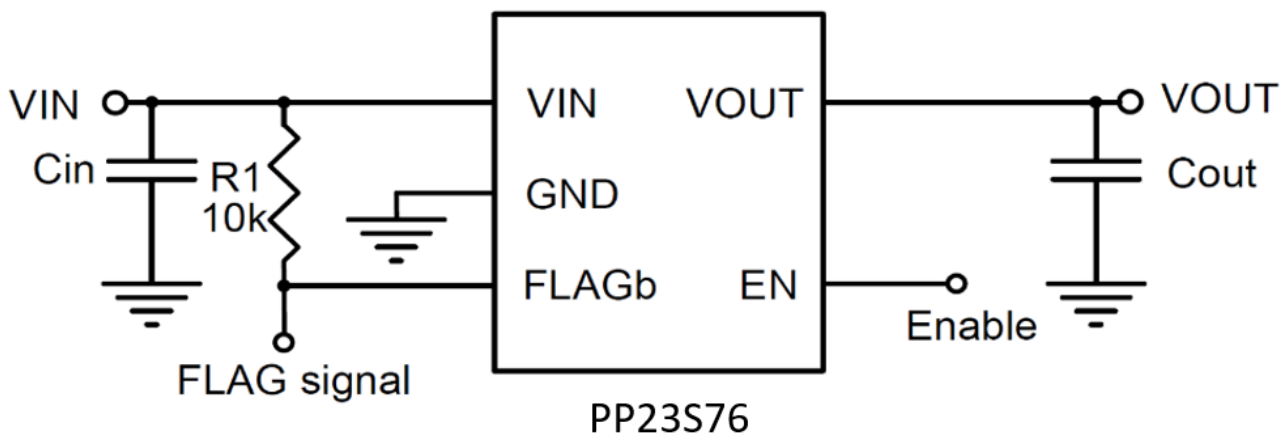

Power Switch – PP23S76

Electrical Characteristics

◆ DC characteristics:

Absolute Maximum Ratings

PARAMETER		SYMBOL	RATINGS	UNIT
VIN to GND Voltage		V _{IN}	-0.3 ~ 6	V
VOUT to GND Voltage		V _{OUT}	-0.3 ~ 6	V
FLAGb to GND Voltage		V _{FLAGb}	-0.3 ~ 6	V
EN/ENb to GND Voltage		V _{EN}	-0.3 ~ 6	V
Power Dissipation, T _A =25 °C	SOT23-5	P _D	0.4	W
	TSOT23-5	P _D	0.66	W
	MSOP8	P _D	0.625	W
Thermal Resistance, Junction to Ambient	SOT23-5	R _{θJA}	250	°C/W
	TSOT23-5	R _{θJA}	150	°C/W
	MSOP8	R _{θJA}	160	°C/W
Maximum Junction Temperature		T _J	150	°C
Storage Temperature		T _S	-65 ~ 150	°C
Maximum Lead Soldering Temperature (10 Seconds)		T _L	260	°C
Electrostatic Discharge	HBM (Human Body Model), MIL-STD-883G MTHD 3015.7		± 2000	V
	MM (Machine Model), JEDEC EIA / JESD22-A115		± 200	V

Note: If ICs are stressed beyond the limits listed in the “Absolute Maximum Ratings”, they may be permanently destroyed. These are stress ratings only and functional operation of the device at these or any other condition beyond those indicated under “Recommended Operating Conditions” is not implied. Exposure to absolute maximum rated conditions for extended periods may affect device reliability.

◆ Recommended Operating Conditions

VIN Input Voltage	3.0 V ~ 5.5 V
All other pins	0V ~ 5.5 V
Ambient Temperature Range	-40 °C ~ 85 °C
Junction Temperature Range	-40 °C ~ 125 °C

Power Switch – PP23S76

◆ **Electrical characteristics:**

Unless otherwise specified, these specifications apply over $V_{IN} = 5\text{ V}$, $C_{IN} = 1\ \mu\text{F}$, $C_{OUT} = 0.1\ \mu\text{F}$, and $T_A = 25\ ^\circ\text{C}$.

PARAMETER	SYMBOL	TEST CONDITIONS	MIN.	TYP.	MAX.	UNIT
VIN Quiescent Current	I_Q	$V_{IN} = 5\text{ V}$, EN enable		80	120	μA
VIN Shutdown Current	I_{SD}	$V_{IN} = 5\text{ V}$, EN disable			1	μA
VOU Reverse Leakage Current	I_{REV}	$V_{OUT} = 5.5\text{ V}$, $V_{IN} = 0\text{V}$, EN disable			1	μA
UVLO Threshold	V_{UVLO_H}	V_{IN} rising		2.7	2.9	V
	V_{HYS}	Hysteresis		0.2		V
On Resistance	$R_{DS(ON)}$	$V_{IN} = 5\text{ V}$, $I_{OUT} = 1\text{ A}$		60	75	$\text{m}\Omega$
		PP23S76K/L only		55	70	$\text{m}\Omega$
VOU Discharge Resistance	R_{DIS}	EN disable		170	250	Ω
Over Current Threshold	I_{LIM}	PP23S76A/B_1.0A	1.2	1.5	2.2	A
		PP23S76I/J_1.5A	1.7	2.0	2.7	A
		PP23S76C/D_2.0A	2.2	2.5	3.0	A
		PP23S76E/F/G/H_2.5A	2.8	3.3	4.6	A
		PP23S76K/L_3A	3.3	3.8	5.0	A
VOU Rise Time	t_R	$V_{IN} = 5\text{ V}$, $R_{LOAD} = 10\ \Omega$, $C_{OUT} = 0.1\ \mu\text{F}$, 90 % Setting		0.9		ms
Turn On Delay Time	t_{D_ON}	$V_{IN} = 5\text{ V}$, $R_{LOAD} = 10\ \Omega$, $C_{OUT} = 0.1\ \mu\text{F}$, 50 % of EN to 10% of VOU		150		μs
EN/ENb Logic High Voltage	V_{EN_H}		1.2			V
EN/ENb Logic Low Voltage	V_{EN_L}				0.4	V
EN/ENb Leakage Current	I_{EN}				1	μA
FLAGb Output Low Voltage	V_{FLAGb_L}	$I_{FLAGb} = 1\text{ mA}$			100	mV
FLAGb OFF-state Leakage Current	I_{FLAGb}	$V_{FLAGb} = 5.5\text{ V}$			1	μA
FLAGb Rising and Falling Deglitch Note1	t_{DEG_FLAGb}		5	8	15	ms
Thermal Shutdown Threshold ¹	T_{SD}			150		$^\circ\text{C}$
	T_{HYS}	Hysteresis		20		$^\circ\text{C}$

Note

1. Design guarantee.

Power Switch – PP23S76

Typical Performance Characteristics

Fig 1 - Enable Response, VIN = 5.0 V, without RL

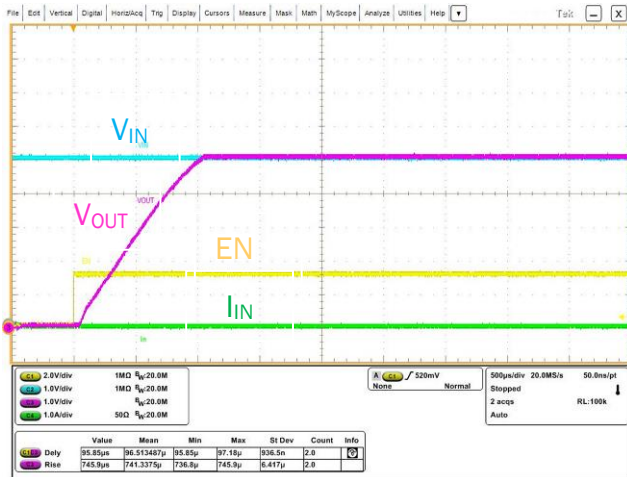

Fig 2 - Enable Response, VIN=5.0 V, RL = 2 Ω

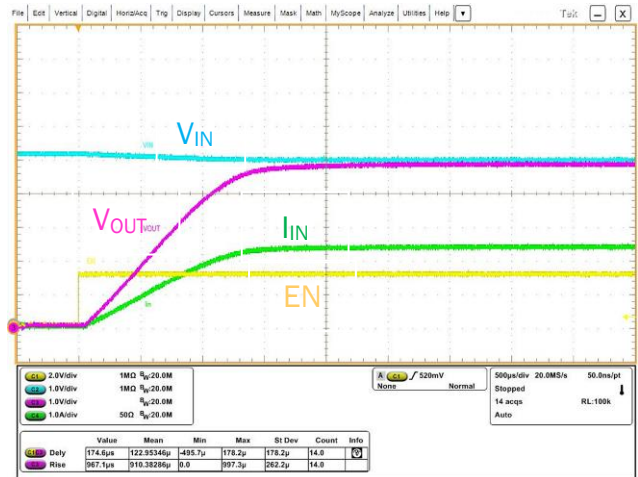

Fig 3 - OCP Response, 2.5 A version, VIN = 3 V

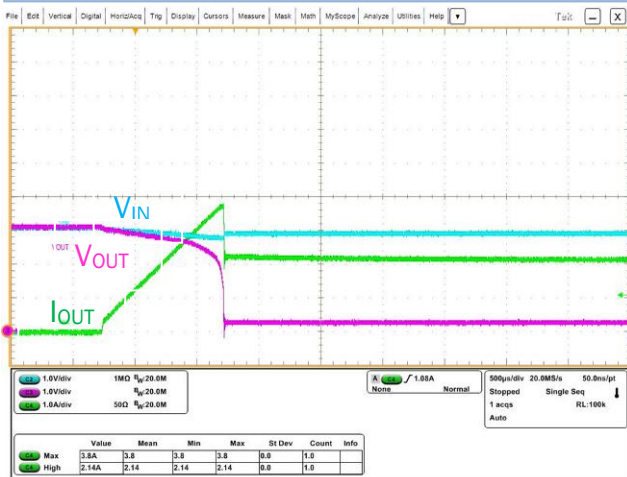

Fig 4 - OCP Response, 2.5 A version, VIN = 5 V

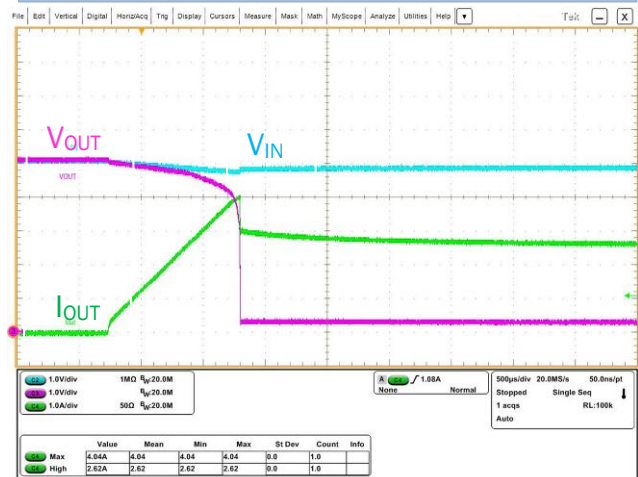

Fig 5 - RCP Response, VIN = 3 V

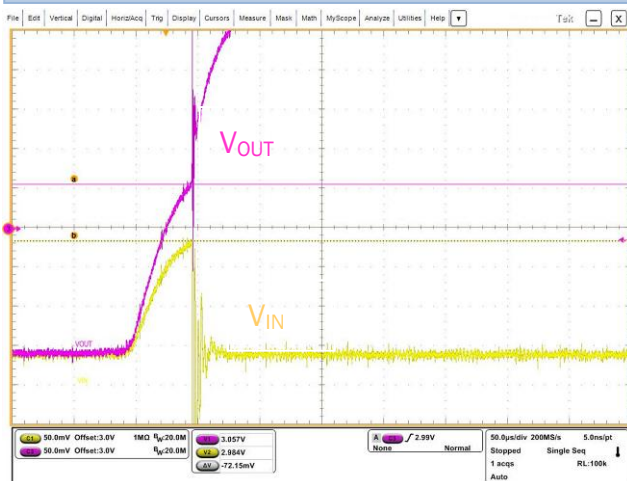
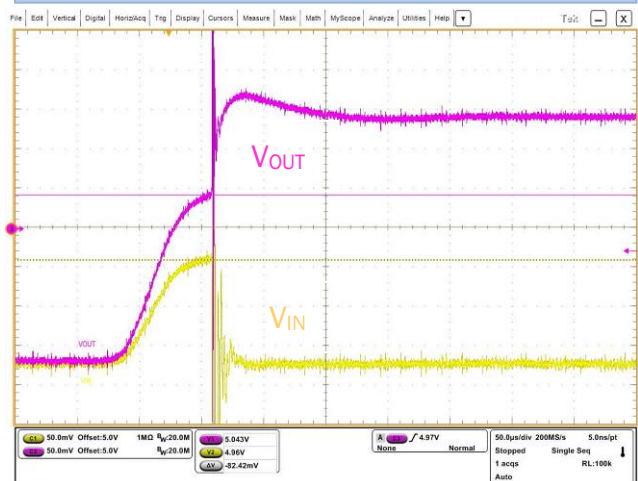

Fig 6 - RCP Response, VIN = 5 V



Power Switch – PP23S76

Fig 7 - VOUT Reverse Blocking



Fig 8 - Output Voltage vs. Output Current

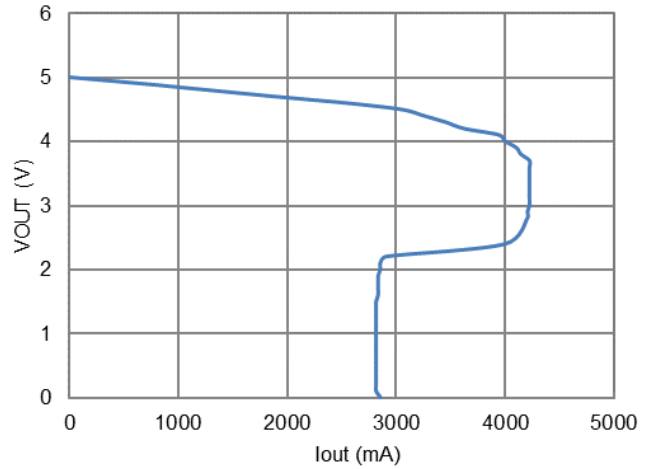

Fig 9 - Quiescent Current vs. Temperature

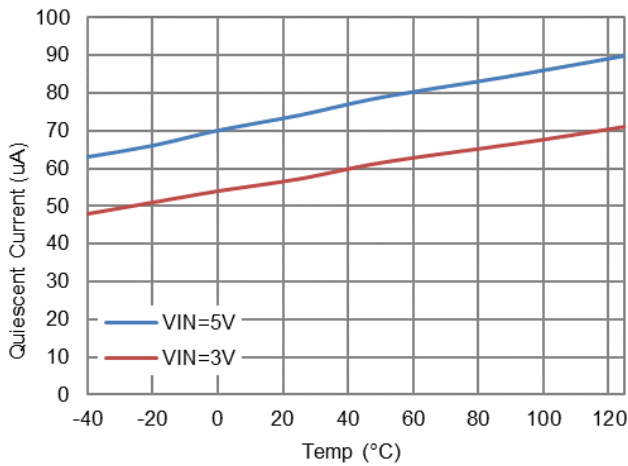

Fig 10 - UVLO vs. Temperature

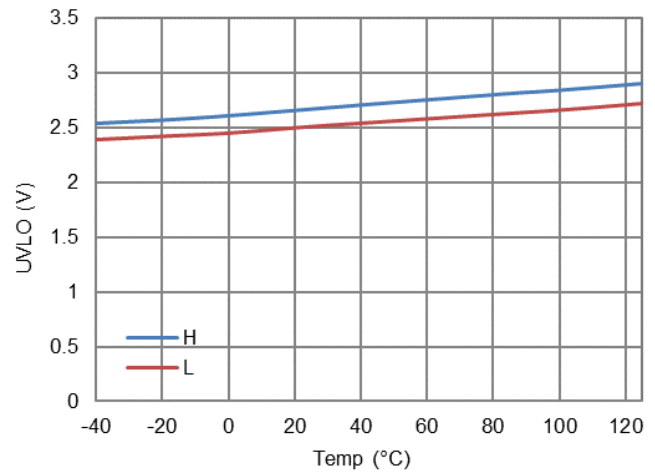

Fig 11 - RDS(ON) vs. Temperature

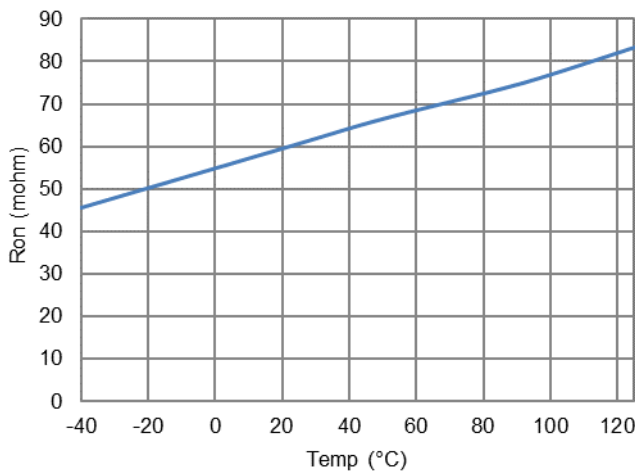
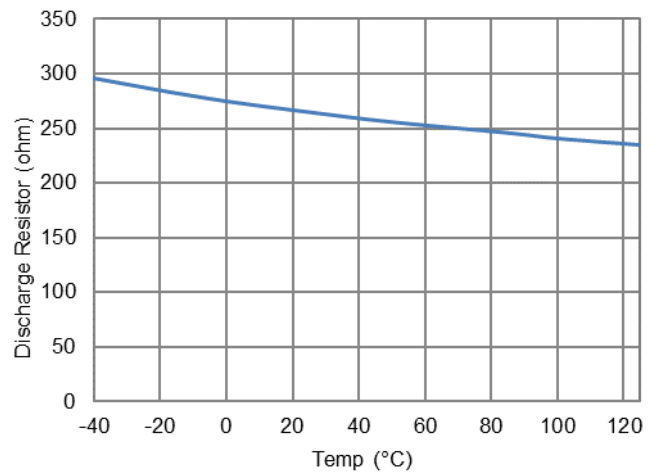

Fig 12 - Rdis vs. Temperature



Power Switch – PP23S76

Part Number Code

PP 23S76 A A5R

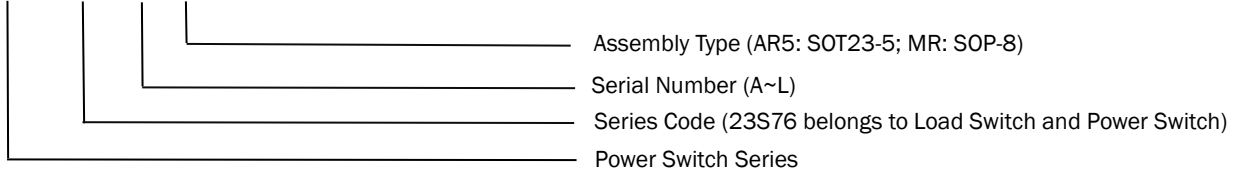

Ordering Information

P/N	Package	Enable	Output Current	Top Side Marking
PP23S76AA5R	SOT23-5	Active High	1A	23S7A YWZZ
PP23S76BA5R	SOT23-5	Active Low	1A	23S7B YWZZ
PP23S76CA5R	SOT23-5	Active High	2A	23S7C YWZZ
PP23S76DA5R	SOT23-5	Active Low	2A	23S7D YWZZ
PP23S76EA5R	SOT23-5	Active High	2.5A	23S7E YWZZ
PP23S76FA5R	SOT23-5	Active Low	2.5A	23S7F YWZZ
PP23S76GMR	MSOP-8	Active High	2.5A	23S7G YWZZ
PP23S76HMR	MSOP-8	Active Low	2.5A	23S7H YWZZ
PP23S76IA5R	SOT23-5	Active High	1.5A	23S7I YWZZ
PP23S76JA5R	SOT23-5	Active Low	1.5A	23S7J YWZZ
PP23S76KA5R	TSOT23-5	Active High	3A	23S7K YWZZ
PP23S76LA5R	TSOT23-5	Active Low	3A	23S7L YWZZ

Marking Definition

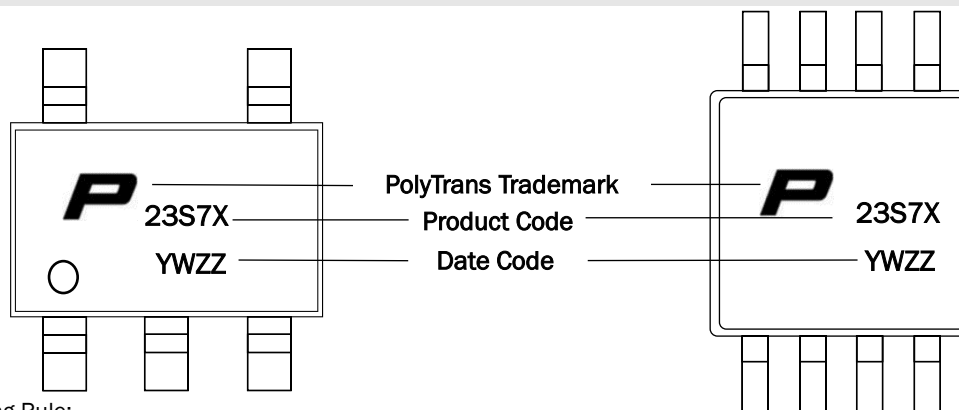

Topside Marking Rule:

Y : Year 2022→I、2023→J; W : Week 01~26→A~Z、27~52→a~z、53→0; ZZ : Series Code

Power Switch – PP23S76

Package Dimension

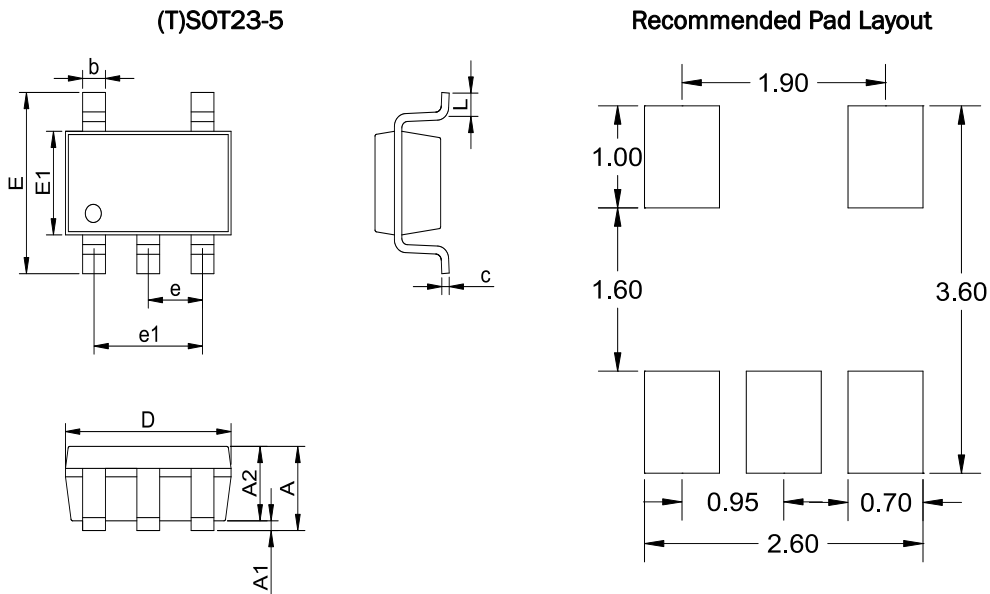

SYMBOLS		MILLIMETERS		INCHES	
		MIN.	MAX.	MIN.	MAX.
A	SOT23-5	-	1.45	-	0.057
	TSOT23-5	0.00	1.10	0.000	0.043
A1	SOT23-5	0.00	0.15	0.000	0.006
	TSOT23-5	0.00	0.10	0.000	0.004
A2	SOT23-5	0.90	1.30	0.036	0.050
	TSOT23-5	0.70	1.00	0.028	0.039
b		0.30	0.50	0.012	0.020
c		0.08	0.22	0.003	0.090
D		2.80	3.00	0.112	0.118
E		2.65	2.95	0.104	0.116
E1		1.50	1.70	0.061	0.066
e		0.95 BSC		0.037 BSC	
e1		1.90 BSC		0.075 BSC	
L		0.30	0.60	0.012	0.024

Power Switch – PP23S76

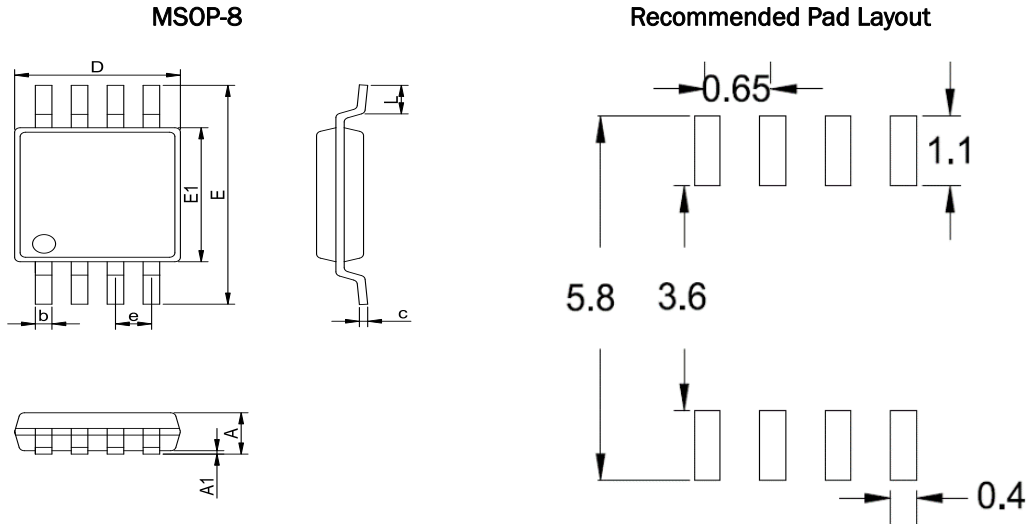

SYMBOLS	MILLIMETERS		INCHES	
	MIN.	MAX.	MIN.	MIN.
A	-	1.10	-	0.043
A1	0.05	0.15	0.002	0.006
b	0.22	0.38	0.009	0.015
c	0.08	0.23	0.003	0.009
D	3.00 BSC		0.118 BSC	
E	4.90 BSC		0.193 BSC	
E1	3.00 BSC		0.118 BSC	
e	0.65 BSC		0.026 BSC	
L	0.40	0.80	0.016	0.031

Note: All dimensions are in millimeters.

Reflow Soldering Recommendations

Preheat	
- Temperature Min (T_{s_min})	150 °C
- Temperature Max (T_{s_max})	200 °C
- Time (T_{s_min} to T_{s_max})	60-180 seconds
- Average Ramp-Up Rate	1~3 °C/second
Peak Temperature	260 °C max.
Time within 5 °C of actual Peak Temperature (t_p)	40 seconds max.
Ramp-Down Rate	6 °C /second max.
Time 25 °C to Peak Temperature	8 minutes max.

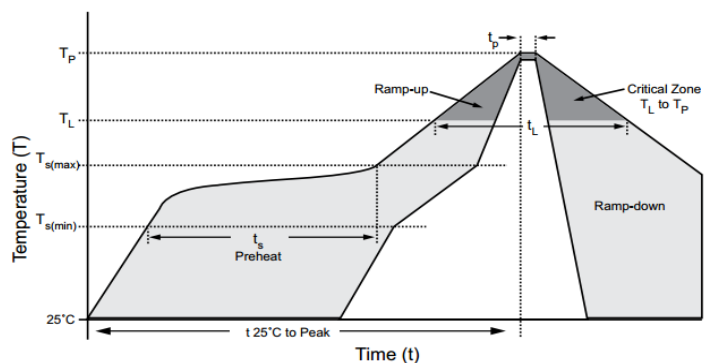

Note: If the soldering temperatures exceed the recommended profile, devices may not meet the performance requirements.

Power Switch – PP23S76

Packaging Information

Part Number	Component Package	Quantity	Packaging Option	Packaging Specification
PP23S76 Series	SOT23-5	3000	Tape & Reel – 8 mm tape/7" reel	EIA STD RS-481
PP23S76 Series	TSOT23-5	3000	Tape & Reel – 8 mm tape/7" reel	EIA STD RS-481
PP23S76 Series	MSOP-8	3000	Tape & Reel – 12 mm tape/13" reel	EIA STD RS-481

Taping and Reel Specification

◆ SOT23-5&TSOT23-5

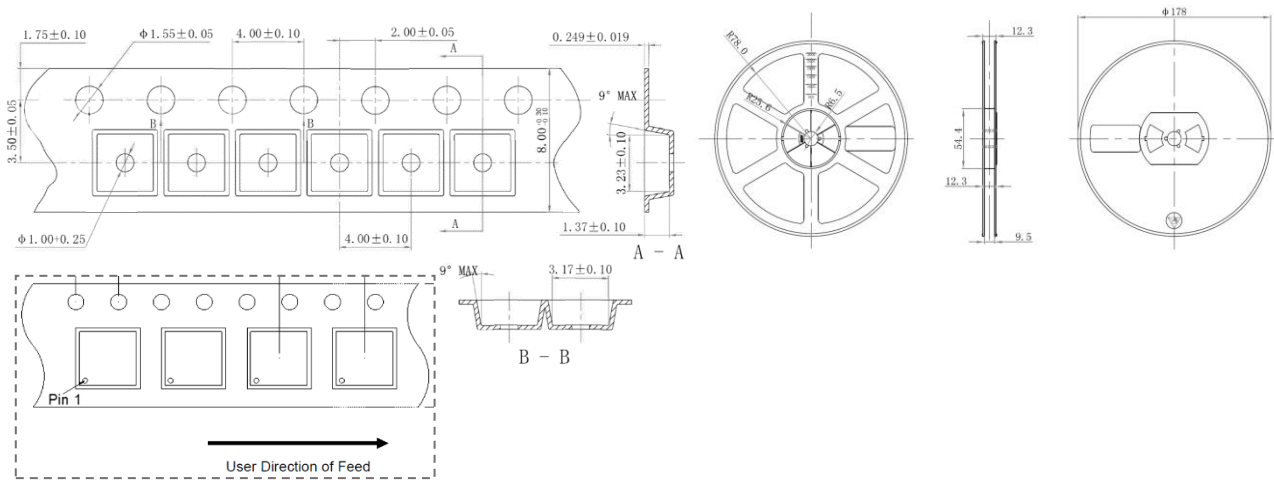

◆ MSOP-8

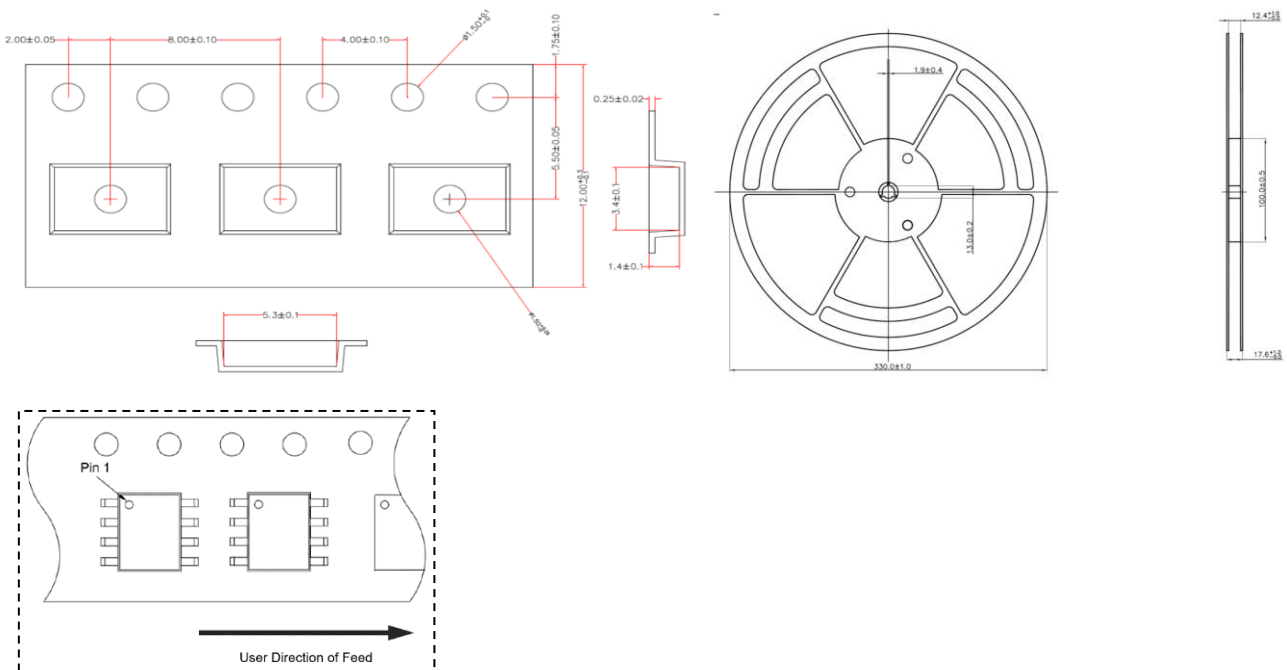

Unit : mm