

TVS Diode – TPSMAJ Series

Features

- Plastic package, excellent insulation strength.
- Glass passivated chip junction in SMA package.
- Excellent voltage clamping capability.
- Automotive grade AEC-Q101 qualified.
- Low Zener impedance.
- 400W peak pulse power capability on 10/1000μs waveform.
- Typical leakage current less than 1μA above 13V.
- Very fast response time, typically less than 1.0ps from 0 volt to V_{BR} minimum.
- High temperature soldering guaranteed: 265°C/10 sec.
- MSL: JEDEC-J-STD-020, Level 1

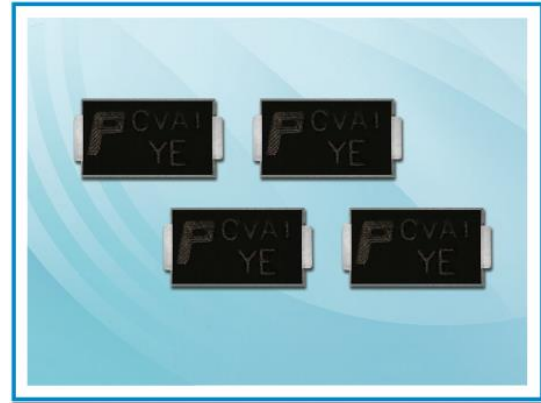

Applications

- I/O interface, V_{CC} bus
- Telecom / Automotive
- Industrial and consumer electronic applications.
- Relay and electromagnetic valve surge absorption.

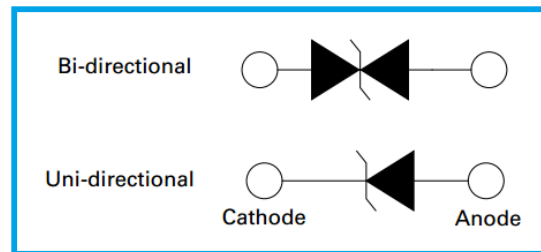

Mechanical and Physical Data

- Case: JEDEC SMA molded plastic.
- Surface mount device, solderable per MIL-STD-750, Method 2026
- Polarity: Color band denoted cathode except bidirectional.

Maximum Ratings and Thermal Characteristics

Parameter	Symbol	Value	Unit
Peak Pulse Power Dissipation on 10/1000μs waveform (Note 1, Fig.1).	P _{PPM}	Min 400	Watt
Peak Pulse Current of 10/1000μs waveform (Note 1, Fig.3).	I _{PPM}	See Table	Amp
Steady State Power Dissipation at T _L = 75°C, Lead lengths 0.375", (9.5mm) (Fig.5).	P _{M(AV)}	3.3	Watt
Peak Forward Surge Current, 8.3 ms Single Half Sine Wave Superimposed on Rated Load (Note 2, Fig.6).	I _{FSM}	40	Amp
Operating Junction and Storage Temperature Range.	T _J , T _{STG}	-55~150	°C

Note:

1. Non-repetitive current pulse, per Fig.3 and derated above T_A = 25°C per Fig.2.
2. 8.3ms single half sine wave, or equivalent square wave, Duty cycle = 4 pulses per minutes maximum.

Part Number Code

TPSMAJ □□□ **C A**

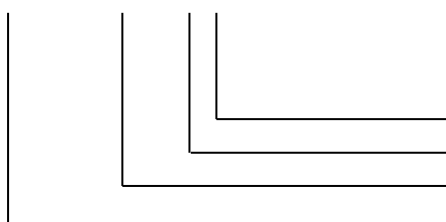

- V_{BR} Voltage tolerance (A: 5%; Blank: 10%)
- C: Bi-directional; Blank: Uni-directional
- Reverse Stand-Off Voltage or Typical Breakdown Voltage
- Automotive TPSMAJ Series (400W)

TVS Diode – TPSMAJ Series

I-V Curve Characteristics

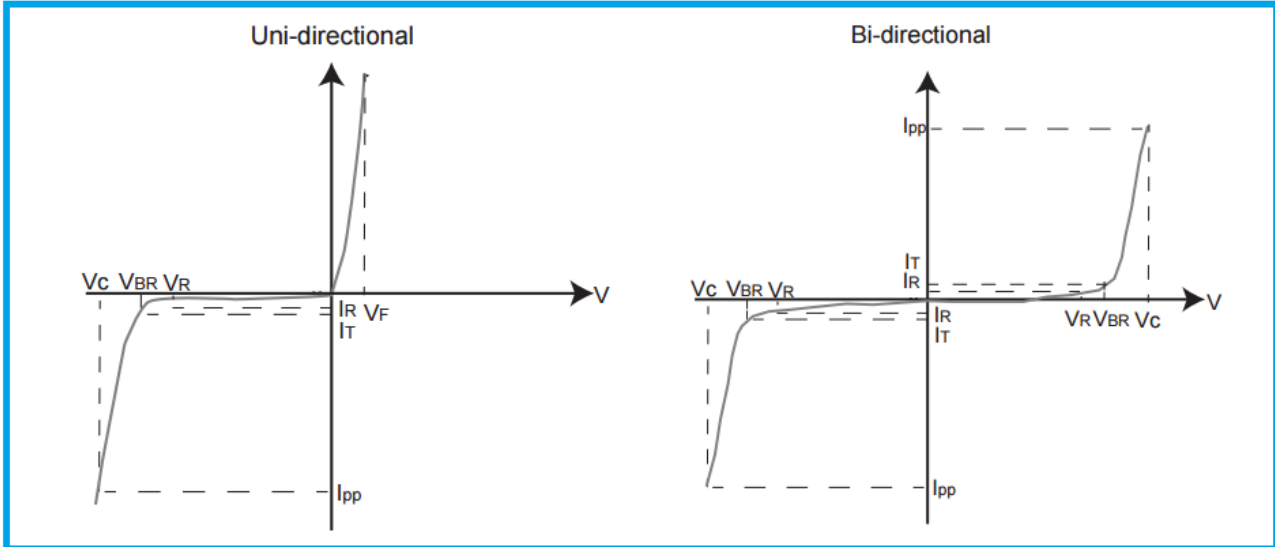

P_{PPM} Peak Pulse Power Dissipation – Maximum power dissipation

V_R Stand-off Voltage – Maximum voltage that can be applied to the TVS without operation

V_{BR} Breakdown Voltage – Maximum voltage that flows through the TVS at a specified test current (I_T)

V_C Clamping Voltage – Peak voltage measured across the TVS at a specified I_{PPM} (Peak Impulse Current)

I_R Reverse Leakage Current – Current measured at V_R

V_F Forward Voltage Drop for Uni-directional

Electrical Characteristics

Part Number		Marking		Reverse Stand Off Voltage V_R (V)	Breakdown Voltage V_{BR} (V) @ I_T		Test Current I_T (mA)	Maximum Clamping Voltage V_C (V) @ I_{PP}	Maximum Peak Pulse Current I_{PP} (A)	Maximum Reverse Leakage I_R (μ A) @ V_R
Uni	Bi	Uni	Bi		Min.	Max.				
TPSMAJ5.0A	TPSMAJ5.0CA	AET	WET	5.0	6.40	7.00	10	9.2	43.48	800
TPSMAJ6.0A	TPSMAJ6.0CA	AGT	WGT	6.0	6.67	7.37	10	10.3	38.83	800
TPSMAJ6.5A	TPSMAJ6.5CA	AKT	WKT	6.5	7.22	7.98	10	11.2	35.71	500
TPSMAJ7.0A	TPSMAJ7.0CA	AMT	WMT	7.0	7.78	8.60	10	12.0	33.33	200
TPSMAJ7.5A	TPSMAJ7.5CA	APT	WPT	7.5	8.33	9.21	1	12.9	31.01	100
TPSMAJ8.0A	TPSMAJ8.0CA	ART	WRT	8.0	8.89	9.83	1	13.6	29.41	50
TPSMAJ8.5A	TPSMAJ8.5CA	ATT	WTT	8.5	9.44	10.40	1	14.4	27.78	10
TPSMAJ9.0A	TPSMAJ9.0CA	AVT	WVT	9.0	10.00	11.10	1	15.4	25.97	5
TPSMAJ10A	TPSMAJ10CA	AXT	WXT	10.0	11.10	12.30	1	17.0	23.53	5
TPSMAJ11A	TPSMAJ11CA	AZT	WZT	11.0	12.20	13.50	1	18.2	21.98	1
TPSMAJ12A	TPSMAJ12CA	BET	XET	12.0	13.30	14.70	1	19.9	20.10	1
TPSMAJ13A	TPSMAJ13CA	BGT	XGT	13.0	14.40	15.90	1	21.5	18.60	1
TPSMAJ14A	TPSMAJ14CA	BKT	XKT	14.0	15.60	17.20	1	23.2	17.24	1
TPSMAJ15A	TPSMAJ15CA	BMT	XMT	15.0	16.70	18.50	1	24.4	16.39	1
TPSMAJ16A	TPSMAJ16CA	BPT	XPT	16.0	17.80	19.70	1	26.0	15.38	1
TPSMAJ17A	TPSMAJ17CA	BRT	XRT	17.0	18.90	20.90	1	27.6	14.49	1
TPSMAJ18A	TPSMAJ18CA	BTT	XTT	18.0	20.00	22.10	1	29.2	13.70	1

TVS Diode – TPSMAJ Series

Part Number		Marking		Reverse Stand Off Voltage V_R (V)	Breakdown Voltage V_{BR} (V) @ I_T		Test Current I_T (mA)	Maximum Clamping Voltage V_C (V) @ I_{PP}	Maximum Peak Pulse Current I_{PP} (A)	Maximum Reverse Leakage I_R (μ A) @ V_R
Uni	Bi	Uni	Bi		Min.	Max.				
TPSMAJ19A	TPSMAJ19CA	BBT	XBT	19.0	21.10	23.30	1	30.8	13.00	1
TPSMAJ20A	TPSMAJ20CA	BVT	XVT	20.0	22.20	24.50	1	32.4	12.35	1
TPSMAJ22A	TPSMAJ22CA	BXT	XXT	22.0	24.40	26.90	1	35.5	11.27	1
TPSMAJ24A	TPSMAJ24CA	BZT	XZT	24.0	26.70	29.50	1	38.9	10.28	1
TPSMAJ26A	TPSMAJ26CA	CET	YET	26.0	28.90	31.90	1	42.1	9.50	1
TPSMAJ28A	TPSMAJ28CA	CGT	YGT	28.0	31.10	34.40	1	45.4	8.81	1
TPSMAJ30A	TPSMAJ30CA	CKT	YKT	30.0	33.30	36.80	1	48.4	8.26	1
TPSMAJ33A	TPSMAJ33CA	CMT	YMT	33.0	36.70	40.60	1	53.3	7.50	1
TPSMAJ36A	TPSMAJ36CA	CPT	YPT	36.0	40.00	44.20	1	58.1	6.88	1
TPSMAJ40A	TPSMAJ40CA	CRT	YRT	40.0	44.40	49.10	1	64.5	6.20	1
TPSMAJ43A	TPSMAJ43CA	CTT	YTT	43.0	47.80	52.80	1	69.4	5.76	1
TPSMAJ45A	TPSMAJ45CA	CVT	YVT	45.0	50.00	55.30	1	72.7	5.50	1
TPSMAJ48A	TPSMAJ48CA	CXT	YXT	48.0	53.30	58.90	1	77.4	5.17	1
TPSMAJ51A	TPSMAJ51CA	CZT	YZT	51.0	56.70	62.70	1	82.4	4.89	1
TPSMAJ54A	TPSMAJ54CA	RET	ZET	54.0	60.00	66.30	1	87.1	4.59	1
TPSMAJ58A	TPSMAJ58CA	RGT	ZGT	58.0	64.40	71.20	1	93.6	4.27	1
TPSMAJ60A	TPSMAJ60CA	RKT	ZKT	60.0	66.70	73.70	1	96.8	4.13	1
TPSMAJ64A	TPSMAJ64CA	RMT	ZMT	64.0	71.10	78.60	1	103.0	3.88	1
TPSMAJ70A	TPSMAJ70CA	RPT	ZPT	70.0	77.80	86.00	1	113.0	3.54	1
TPSMAJ75A	TPSMAJ75CA	RRT	ZRT	75.0	83.30	92.10	1	121.0	3.31	1
TPSMAJ78A	TPSMAJ78CA	RTT	ZTT	78.0	86.70	95.80	1	126.0	3.17	1
TPSMAJ80A	TPSMAJ80CA	RBT	ZBT	80.0	88.80	97.60	1	129.6	3.09	1
TPSMAJ85A	TPSMAJ85CA	RVT	ZVT	85.0	94.40	104.0	1	137.0	2.92	1
TPSMAJ90A	TPSMAJ90CA	RXT	ZXT	90.0	100.0	111.0	1	146.0	2.7	1
TPSMAJ100A	TPSMAJ100CA	RZT	ZZT	100.0	111.0	123.0	1	162.0	2.5	1
TPSMAJ110A	TPSMAJ110CA	SET	VET	110.0	122.0	135.0	1	177.0	2.3	1
TPSMAJ120A	TPSMAJ120CA	SGT	VGT	120.0	133.0	147.0	1	193.0	2.1	1
TPSMAJ130A	TPSMAJ130CA	SKT	VKT	130.0	144.0	159.0	1	209.0	1.9	1
TPSMAJ150A	TPSMAJ150CA	SMT	VMT	150.0	167.0	185.0	1	243.0	1.6	1
TPSMAJ160A	TPSMAJ160CA	SPT	VPT	160.0	178.0	197.0	1	259.0	1.5	1
TPSMAJ170A	TPSMAJ170CA	SRT	VRT	170.0	189.0	209.0	1	275.0	1.5	1
TPSMAJ180A	TPSMAJ180CA	STT	VTT	180.0	201.0	222.0	1	292.0	1.4	1
TPSMAJ190A	TPSMAJ190CA	SUT	YUT	190.0	209.0	243.0	1	308.0	1.3	1
TPSMAJ200A	TPSMAJ200CA	SVT	VVT	200.0	224.0	247.0	1	324.0	1.2	1
TPSMAJ220A	TPSMAJ220CA	SXT	VXT	220.0	246.0	272.0	1	356.0	1.1	1
TPSMAJ250A	TPSMAJ250CA	SZT	VZT	250.0	279.0	309.0	1	405.0	1.0	1
TPSMAJ300A	TPSMAJ300CA	TET	UET	300.0	335.0	371.0	1	486.0	0.8	1
TPSMAJ350A	TPSMAJ350CA	TGT	UGT	350.0	391.0	432.0	1	567.0	0.7	1
TPSMAJ400A	TPSMAJ400CA	TKT	UKT	400.0	447.0	494.0	1	648.0	0.6	1
TPSMAJ440A	TPSMAJ440CA	TMT	UMT	440.0	492.0	543.0	1	713.0	0.6	1

Note:

1. For bi-directional type having V_R of 10 volts and less, the I_R limit is double.

TVS Diode – TPSMAJ Series

Ratings and Characteristic Curves

Fig 1 - Peak Pulse Power Rating Curve

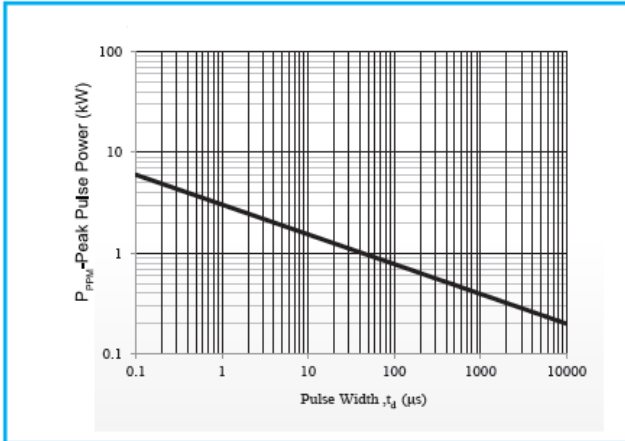

Fig 2 - Pulse Derating Curve

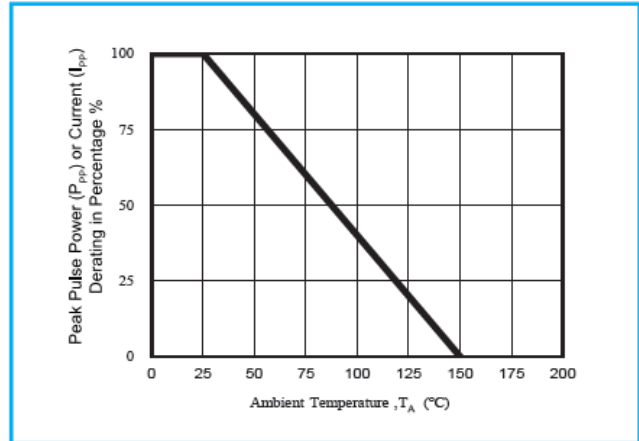

Fig 3 - Pulse Waveform

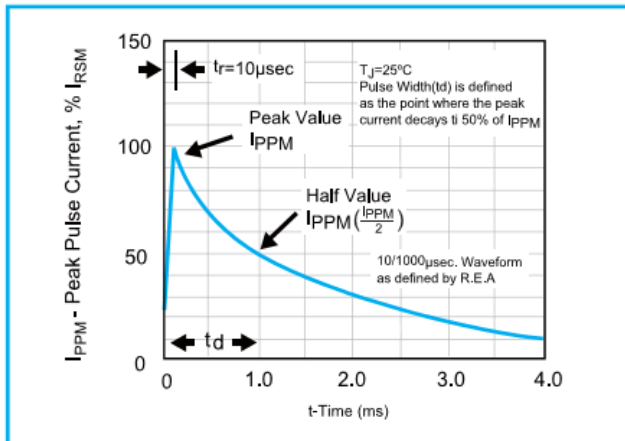

Fig 4 - Typical Junction Capacitance Uni-directional

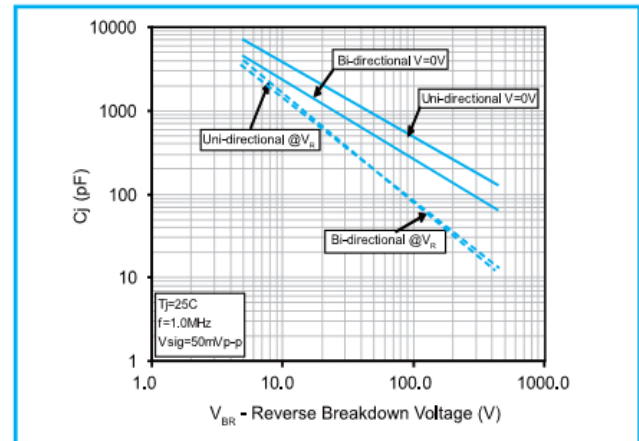

Fig 5 - Steady State Power Dissipation Derating Curve

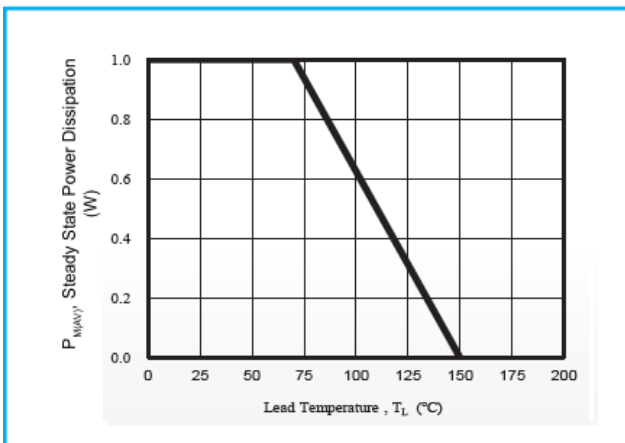
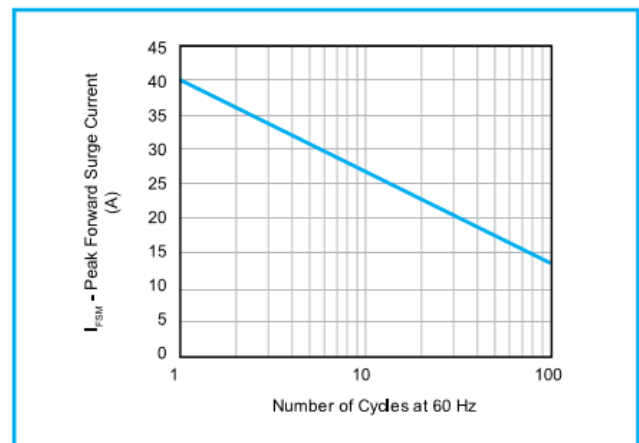
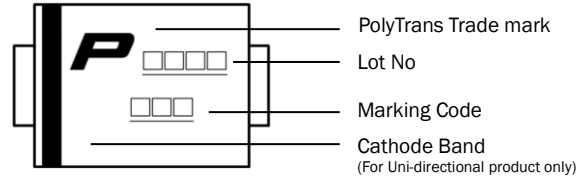

Fig 6 - Maximum Non-Repetitive Forward Surge Current (Uni-directional Only)



TVS Diode – TPSMAJ Series

Marking Definitions



Physical Dimensions

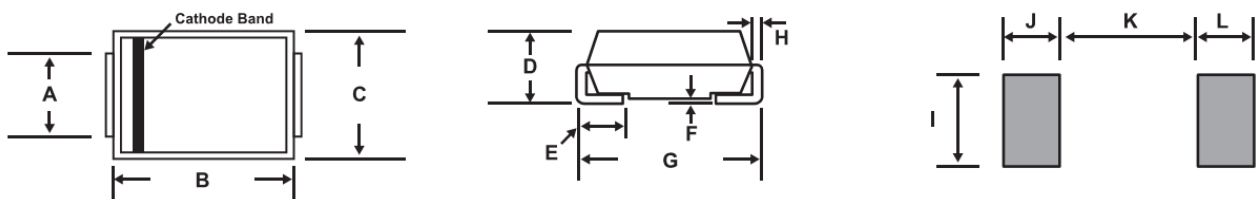

Dimension	Millimeters		Inches	
	Min	Max	Min	Max
A	1.25	1.65	0.049	0.065
B	3.99	4.60	0.157	0.177
C	2.50	2.90	0.100	0.110
D	1.98	2.29	0.078	0.090
E	0.78	1.52	0.030	0.060
F	-	0.203	-	0.008
G	4.93	5.28	0.194	0.208
H	0.152	0.305	0.006	0.012
I	1.80	-	0.070	-
J	2.10	-	0.082	-
K	-	2.30	-	0.090
L	2.10	-	0.082	-

Lead Free Reflow Soldering Recommendations

Preheat	
- Temperature Min (T_{s_min})	150°C
- Temperature Max (T_{s_max})	200°C
- Time (T_{s_min} to T_{s_max})	60-180 seconds
- Average Ramp-Up Rate	1~3°C/second
Peak Temperature	260°C max.
Time within 5°C of actual Peak Temperature (t_p)	40 seconds max.
Ramp-Down Rate	6 °C /second max.



Note: If the soldering temperatures exceed the recommended profile, devices may not meet the performance requirements.

TVS Diode – TPSMAJ Series

Packaging Information

Part Number	Component Package	Quantity	Packaging Option	Packaging Specification
TPSMAJ Series	DO-214AC	5000	Tape & Reel – 12mm tape/13" reel	EIA STD RS-481

Tape and Reel Specifications

