

## TVS Diode – 3KP Series

### Features

- Plastic package, excellent insulation strength.
- Glass passivated chip junction in P600 package.
- Excellent voltage clamping capability.
- Low Zener impedance.
- 3000W peak pulse power capability on 10/1000μs waveform.
- Typical leakage current less than 1μA above 13V.
- Very fast response time, typically less than 1.0ps from 0 volt to V<sub>BR</sub> minimum.
- High temperature soldering guaranteed: 265°C/10 sec.
- MSL: JEDEC-J-STD-020, Level 1



### Applications

- I/O interface, V<sub>CC</sub> bus
- Telecom
- Industrial and consumer electronic applications.
- Relay and electromagnetic valve surge absorption.

### Agency Approval

- Pending

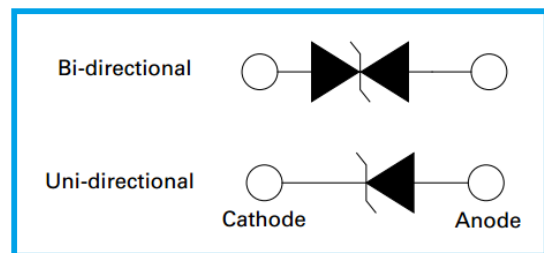

### Mechanical and Physical Data

- Case: JEDEC P600 molded plastic.
- Axial leaded, solderable per MIL-STD-750, Method 2026
- Polarity: Color band denoted cathode except bidirectional.

### Maximum Ratings and Thermal Characteristics

Parameter	Symbol	Value	Unit
Peak Pulse Power Dissipation on 10/1000μs waveform (Note 1, Fig.1).	P <sub>PPM</sub>	Min 3000	Watt
Peak Pulse Current of 10/1000μs waveform (Note 1, Fig.3).	I <sub>PPM</sub>	See Table	Amp
Steady State Power Dissipation at TL = 75°C, Lead lengths 0.375", (9.5mm) (Fig.5).	P <sub>M(AV)</sub>	7.0	Watt
Peak Forward Surge Current, 8.3 ms Single Half Sine Wave Superimposed on Rated Load (Note 2, Fig.6).	I <sub>FSM</sub>	300	Amp
Operating Junction and Storage Temperature Range.	T <sub>J</sub> , T <sub>STG</sub>	-55~175	°C

Note:

1. Non-repetitive current pulse, per Fig.3 and derated above T<sub>A</sub> = 25°C per Fig.2.
2. 8.3ms single half sine wave, or equivalent square wave, Duty cycle = 4 pulses per minutes maximum.

### Part Number Code

3KP □□□ C A - □

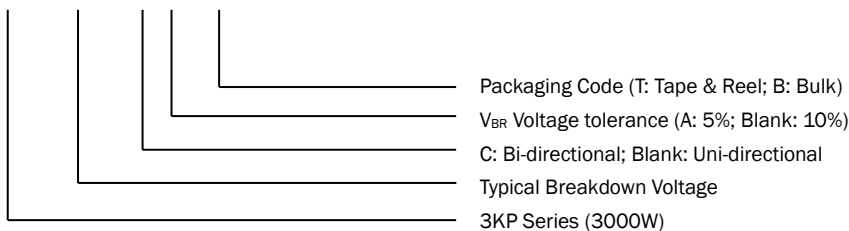

## TVS Diode – 3KP Series

### I-V Curve Characteristics

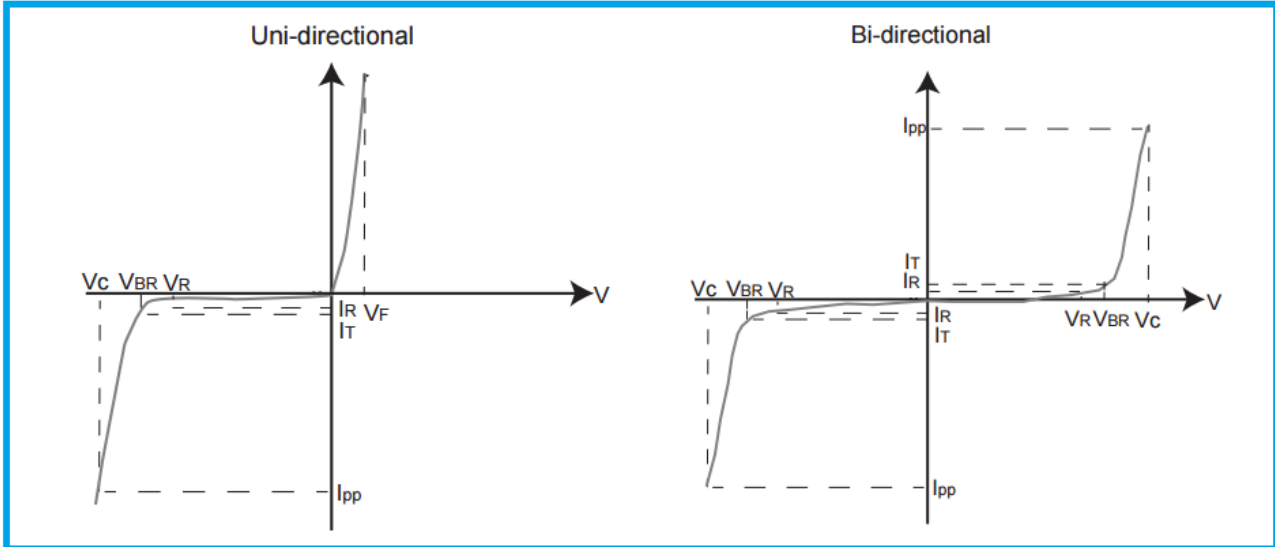

- $I_{PPM}$  Peak Pulse Power Dissipation – Maximum power dissipation
- $V_R$  Stand-off Voltage – Maximum voltage that can be applied to the TVS without operation
- $V_{BR}$  Breakdown Voltage – Maximum voltage that flows through the TVS at a specified test current ( $I_T$ )
- $V_C$  Clamping Voltage – Peak voltage measured across the TVS at a specified  $I_{PPM}$  (Peak Impulse Current)
- $I_R$  Reverse Leakage Current – Current measured at  $V_R$
- $V_F$  Forward Voltage Drop for Uni-directional

### Electrical Characteristics

Part Number		Reverse Stand Off Voltage $V_R$ (V)	Breakdown Voltage $V_{BR}$ (V) @ $I_T$		Test Current $I_T$ (mA)	Maximum Clamping Voltage $V_C$ (V) @ $I_{PP}$	Maximum Peak Pulse Current $I_{PP}$ (A)	Maximum Reverse Leakage $I_R$ ( $\mu$ A) @ $V_R$
Uni	Bi		Min.	Max.				
3KP5.0A	3KP5.0CA	5.0	6.40	7.00	10	9.2	326.1	5000
3KP6.0A	3KP6.0CA	6.0	6.67	7.37	10	10.3	291.3	5000
3KP6.5A	3KP6.5CA	6.5	7.22	7.98	10	11.2	267.9	2000
3KP7.0A	3KP7.0CA	7.0	7.78	8.60	10	12.0	250.0	1000
3KP7.5A	3KP7.5CA	7.5	8.33	9.21	1	12.9	232.6	250
3KP8.0A	3KP8.0CA	8.0	8.89	9.83	1	13.6	220.6	150
3KP8.5A	3KP8.5CA	8.5	9.44	10.4	1	14.4	208.3	50
3KP9.0A	3KP9.0CA	9.0	10.0	11.1	1	15.4	194.8	20
3KP10A	3KP10CA	10.0	11.1	12.3	1	17.0	176.5	15
3KP11A	3KP11CA	11.0	12.2	13.5	1	18.2	164.8	2
3KP12A	3KP12CA	12.0	13.3	14.7	1	19.9	150.8	2
3KP13A	3KP13CA	13.0	14.4	15.9	1	21.5	139.5	2
3KP14A	3KP14CA	14.0	15.6	17.2	1	23.2	129.3	2
3KP15A	3KP15CA	15.0	16.7	18.5	1	24.4	123.0	2
3KP16A	3KP16CA	16.0	17.8	19.7	1	26.0	115.4	2
3KP17A	3KP17CA	17.0	18.9	20.9	1	27.6	108.7	2
3KP18A	3KP18CA	18.0	20.0	22.1	1	29.2	102.7	2
3KP20A	3KP20CA	20.0	22.2	24.5	1	32.4	92.6	2



## TVS Diode – 3KP Series

Part Number		Reverse Stand Off Voltage $V_R$ (V)	Breakdown Voltage $V_{BR}$ (V) @ $I_T$		Test Current $I_T$ (mA)	Maximum Clamping Voltage $V_C$ (V) @ $I_{PP}$	Maximum Peak Pulse Current $I_{PP}$ (A)	Maximum Reverse Leakage $I_R$ ( $\mu$ A) @ $V_R$
Uni	Bi		Min.	Max.				
3KP22A	3KP22CA	22.0	24.4	26.9	1	35.5	84.5	2
3KP24A	3KP24CA	24.0	26.7	29.5	1	38.9	77.1	2
3KP26A	3KP26CA	26.0	28.9	31.9	1	42.1	71.3	2
3KP28A	3KP28CA	28.0	31.1	34.4	1	45.4	66.1	2
3KP30A	3KP30CA	30.0	33.3	36.8	1	48.4	62.0	2
3KP33A	3KP33CA	33.0	36.7	40.6	1	53.3	56.3	2
3KP36A	3KP36CA	36.0	40.0	44.2	1	58.1	51.6	2
3KP40A	3KP40CA	40.0	44.4	49.1	1	64.5	46.5	2
3KP43A	3KP43CA	43.0	47.8	52.8	1	69.4	43.2	2
3KP45A	3KP45CA	45.0	50.0	55.3	1	72.7	41.3	2
3KP48A	3KP48CA	48.0	53.3	58.9	1	77.4	38.8	2
3KP51A	3KP51CA	51.0	56.7	62.7	1	82.4	36.4	2
3KP54A	3KP54CA	54.0	60.0	66.3	1	87.1	34.4	2
3KP58A	3KP58CA	58.0	64.4	71.2	1	93.6	32.1	2
3KP60A	3KP60CA	60.0	66.7	73.7	1	96.8	31.0	2
3KP64A	3KP64CA	64.0	71.1	78.6	1	103.0	29.1	2
3KP70A	3KP70CA	70.0	77.8	86.0	1	113.0	26.5	2
3KP75A	3KP75CA	75.0	83.3	92.1	1	121.0	24.8	2
3KP78A	3KP78CA	78.0	86.7	95.8	1	126.0	23.8	2
3KP85A	3KP85CA	85.0	94.4	104.0	1	137.0	21.9	2
3KP90A	3KP90CA	90.0	100.0	111.0	1	146.0	20.5	2
3KP100A	3KP100CA	100.0	111.0	123.0	1	162.0	18.5	2
3KP110A	3KP110CA	110.0	122.0	135.0	1	177.0	16.9	2
3KP120A	3KP120CA	120.0	133.0	147.0	1	193.0	15.5	2
3KP130A	3KP130CA	130.0	144.0	159.0	1	209.0	14.4	2
3KP150A	3KP150CA	150.0	167.0	185.0	1	243.0	12.3	2
3KP160A	3KP160CA	160.0	178.0	197.0	1	259.0	11.6	2
3KP170A	3KP170CA	170.0	189.0	209.0	1	275.0	10.9	2
3KP180A	3KP180CA	180.0	201.0	222.0	1	292.0	10.3	2
3KP190A	3KP190CA	190.0	211.0	233.0	1	308.0	9.70	2
3KP200A	3KP200CA	200.0	224.0	247.0	1	324.0	9.30	2
3KP210A	3KP210CA	210.0	237.0	263.0	1	340.0	8.80	2
3KP220A	3KP220CA	220.0	246.0	272.0	1	356.0	8.40	2
3KP250A	3KP250CA	250.0	279.0	309.0	1	425.0	7.10	2
3KP300A	3KP300CA	300.0	335.0	371.0	1	486.0	6.15	2
3KP350A	3KP350CA	350.0	391.0	432.0	1	567.0	5.27	2
3KP400A	3KP400CA	400.0	447.0	494.0	1	658.0	4.55	2
3KP440A	3KP440CA	440.0	492.0	543.0	1	742.2	4.05	2

## TVS Diode – 3KP Series

### Ratings and Characteristic Curves

Fig 1 - Peak Pulse Power Rating Curve

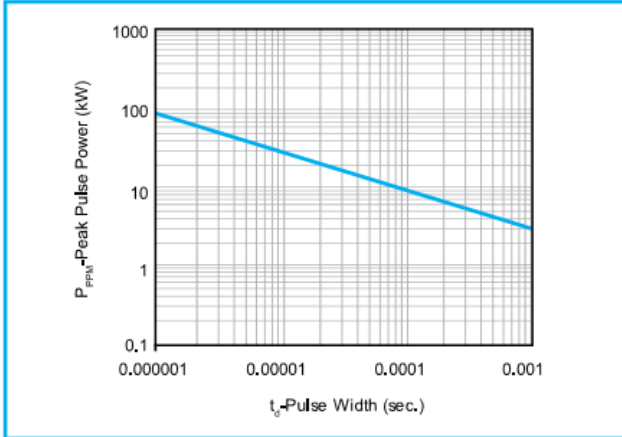

Fig 2 - Pulse Derating Curve

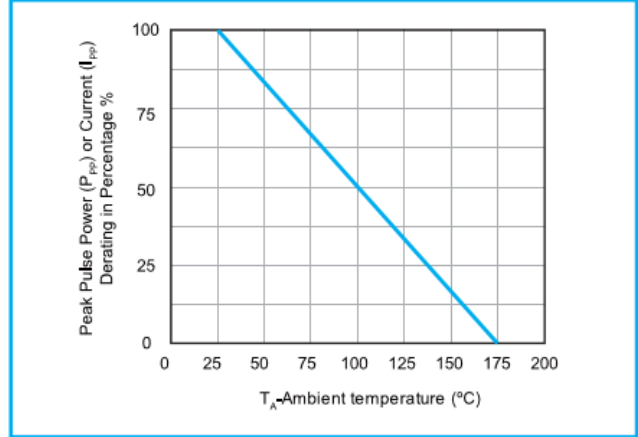

Fig 3 - Pulse Waveform

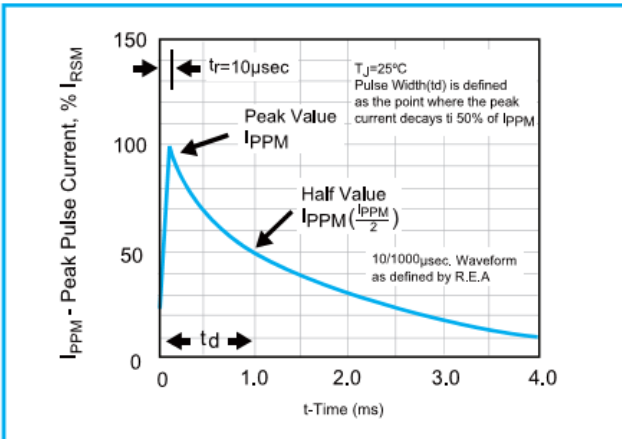

Fig 4 - Typical Junction Capacitance Uni-directional

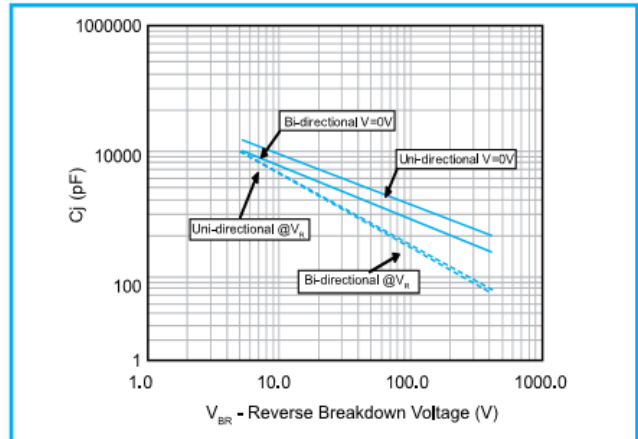

Fig 5 - Steady State Power Dissipation Derating Curve

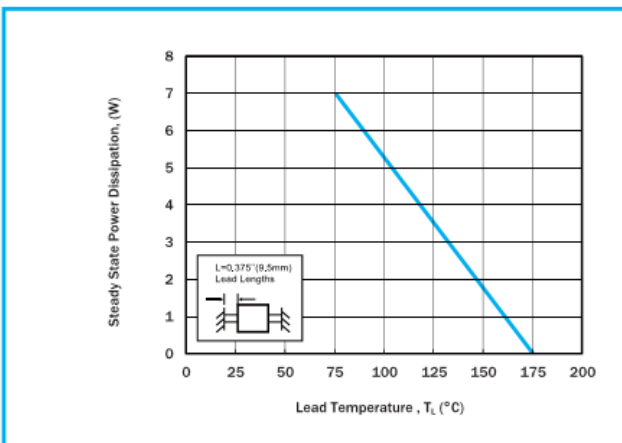
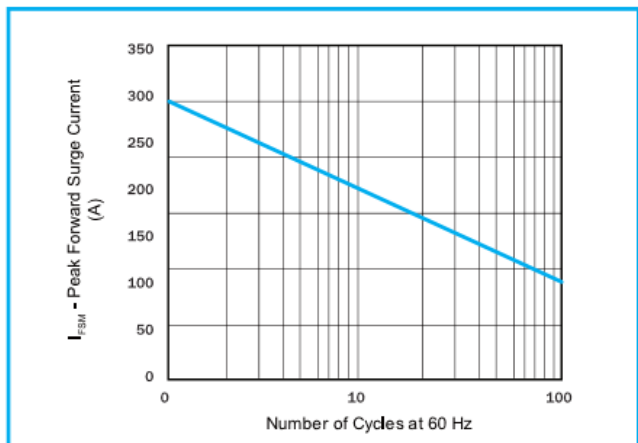
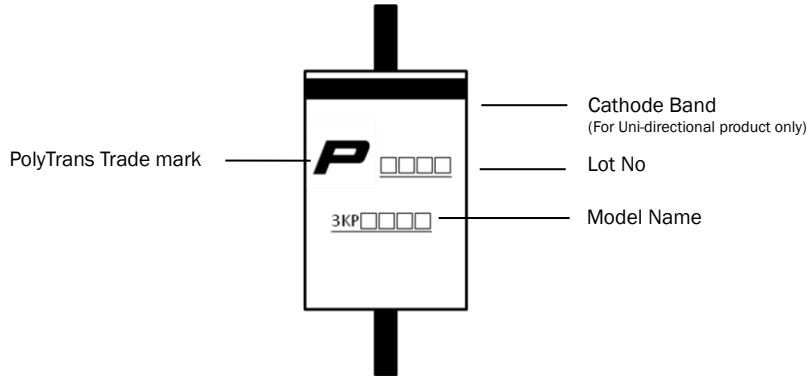

Fig 6 - Maximum Non-Repetitive Forward Surge Current (Uni-directional Only)



## TVS Diode – 3KP Series

### Marking Definitions



### Physical Dimensions

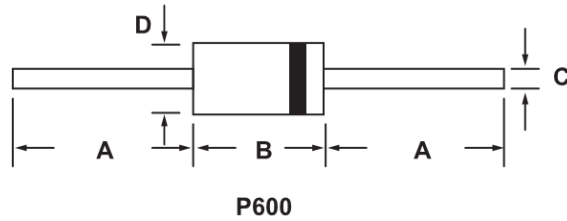

Dimension	Millimeters		Inches	
	Min	Max	Min	Max
A	25.40	-	1.000	-
B	8.60	9.10	0.340	0.360
C	1.22	1.32	0.048	0.052
D	8.60	9.10	0.340	0.360

## TVS Diode – 3KP Series

### Packaging Information

Part Number	Packaging Code	Component Package	Quantity	Packaging Option	Packaging Specification
3KP Series	T	P600	800	Tape & Reel	EIA STD RS-296
3KP Series	B	P600	100	Bulk	-

### Tape and Reel Specifications

